

*** UCPS PRODUCT CUT SHEET ***

| | |
|---------|---------------------------------|
| REV-001 | APPROVED FOR PRODUCTION 1/18/25 |
| | |

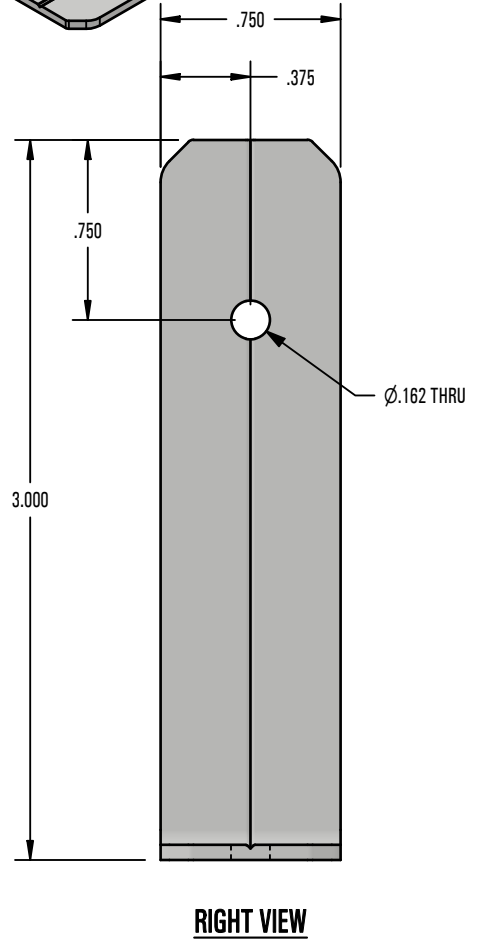
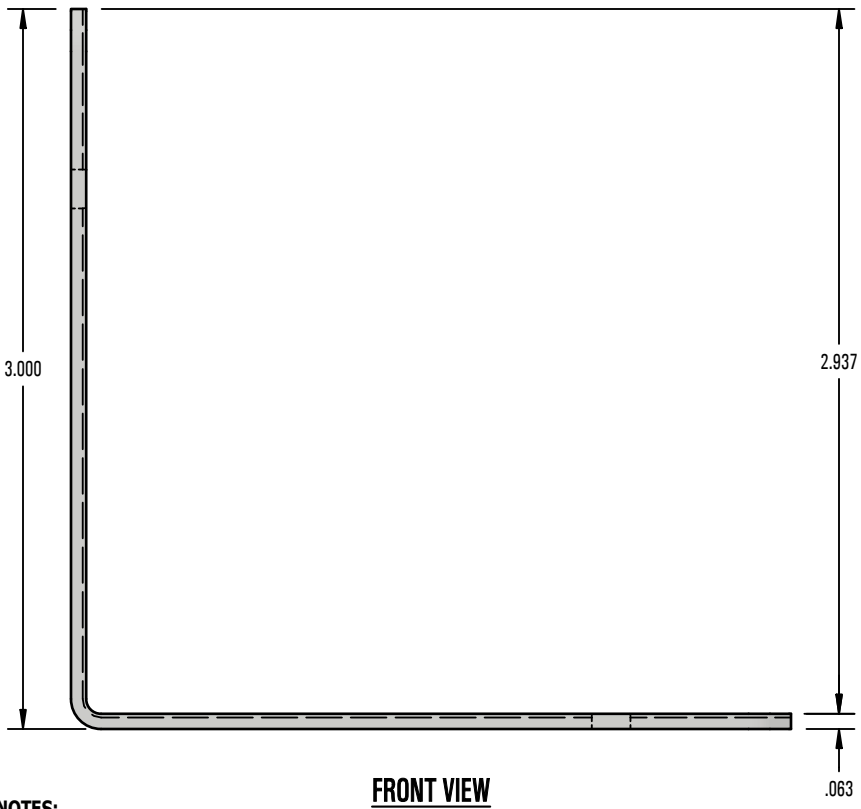
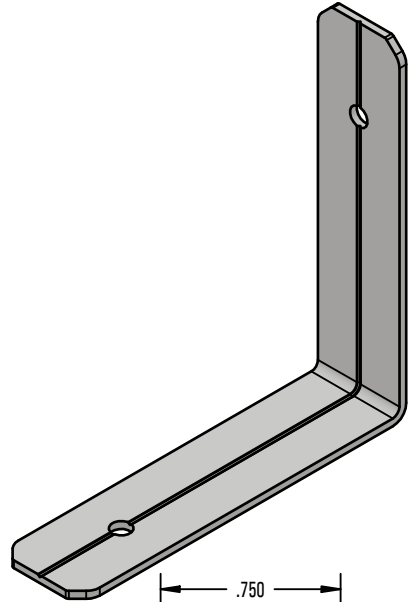
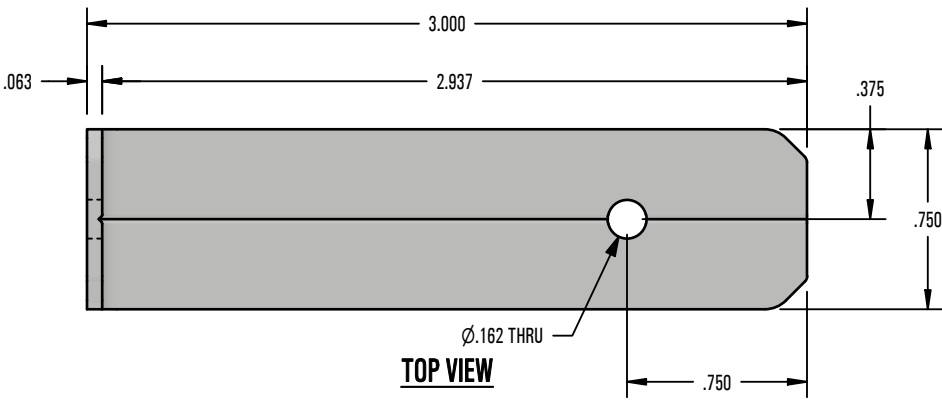

NOTES:

1. FOR CLARITY THIS DRAWING IS NOT TO SCALE.
2. CONTACT THE MANUFACTURER FOR RECOMMENDED LAYOUTS, SPACING AND ADDITIONAL DETAILS.
3. INSTALLATION MUST BE COMPLETED WITH THE MANUFACTURERS WRITTEN SPECIFICATIONS AND INSTALLATION INSTRUCTIONS.
4. THESE DRAWINGS ARE SUBJECT TO CHANGE WITHOUT NOTICE.



UNIVERSAL
COMPOSITE PANEL SYSTEMS™

4800 METALMASTER WAY - McHENRY, IL 60050
PHONE: 800.815.7652 | WEBSITE: WWW.USCPS.US | E-MAIL: INFO@UCPS.COM

RIGHT ANGLE-FORMED

| | |
|-----------|-------------------|
| DRAWN BY: | rhoeffleur |
| DATE: | 1/18/2025 |
| SCALE: | N.T.S. |
| MATERIAL: | Aluminum 5052 H32 |

THE INFORMATION HEREIN IS CONFIDENTIAL AND PROPRIETARY AND IS NOT TO BE DISCLOSED OR DELIVERED TO THIRD PARTIES WITHOUT THE PRIOR WRITTEN CONSENT OF SOLAR CONNECTIONS INTERNATIONAL, INC.